

HUPFER
we make work flow



MEDIFURN FURNISHINGS

Keep things clean and tidy with
innovative hygiene equipment



EXPLORE THE WORLD OF HYGIENIC FURNISHINGS

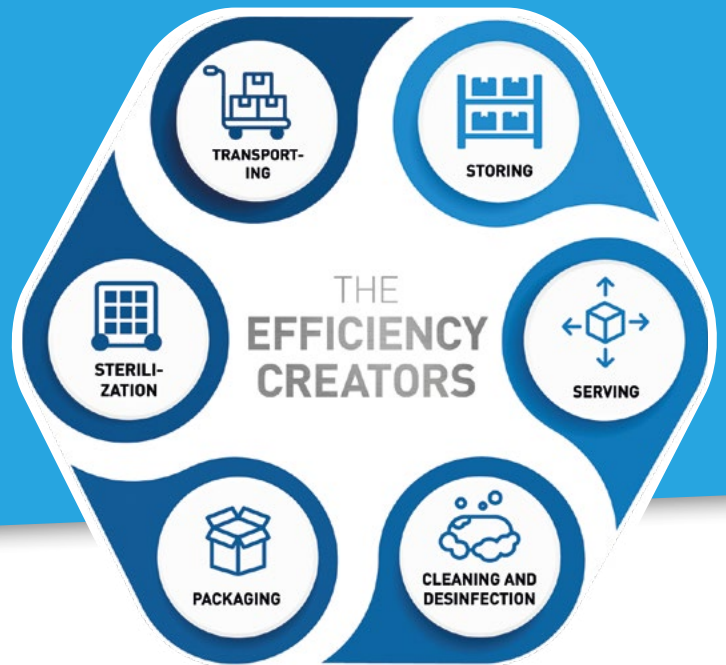

YOUR COMPLETE SOLUTION

Page 4-6

Cleaning table systems

Cleaning tables are subject to particularly stringent hygiene requirements. To optimise hygienic safety, the bodies of the MediFurn cleaning table systems are also available for hygiene levels H1 and H2.



REFERENCE PROJECT
MOC AHLEN

Page 7

Practical proof

Take a look at how our solutions are implemented on site in the projects.



FOR OPTIMAL STORAGE

Page 8-9

Tall cabinets and wall cabinets

Cabinets should not only provide plenty of space for safely storing items, they also need to be tidy, versatile and easy to use.



EFFICIENCY AND ERGONOMICS

Page 10-11

Packing tables

Checking, sorting, cleaning, packaging – packing tables are used for a range of jobs at a single place.

With the innovative MediFurn series, Hupfer as a system partner presents a comprehensive range of hygiene equipment that sets new standards. The new generation of furnishing equipment is impressively functional and attractively designed, and now fully welded to make cleaning easier than ever before and ensure optimal hygiene. MediFurn gives your staff and patients the extra safety that counts.



NUMEROUS
VARIATIONS

Page 12

Sink units

These are used for efficient pre-cleaning of medical instruments.



NUMEROUS VARIATIONS

Page 13

Light tables

The fully welded light tables are illuminated work tables for checking surgical laundry for holes.

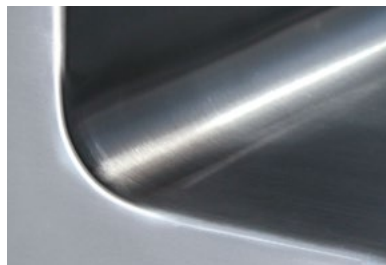

OVERVIEW

Page 14

Hygiene levels

In addition to the usual HS hygiene standard, the bodies of our furnishings are available in the optimised hygienic design types H1 and H2 in accordance with DIN 18865-9.



DETAILS

Page 15

Top quality down to the smallest detail

The high quality of MediFurn equipment is reflected in its clever design and its many useful details.

CLEANING TABLE SYSTEMS YOUR COMPLETE SOLUTION

Cleaning tables are subject to particularly stringent hygiene requirements. To optimise hygienic safety, on request we make bodies for our MediFurn cleaning table systems that meet **hygiene levels H1 and H2**. The fully welded design prevents cavities where dirt may accumulate, making the equipment much easier to clean.

Extraction system , e.g. for ultrasonic baths or steamers.

The **individual modules** (sink module, cabinet with doors, drawers etc.) are available in various sizes and designs as required.



**HYGIENE
STUFE
H2**

**HYGIENE
STUFE
H1**

**HYGIENE
STUFE
HS**

Available in various hygiene levels. For more details see page 14



We offer a wide range of accessories for cleaning table systems, such as air jets, spray attachments, splash guards and ultrasonic baths.



Basins are available in a range of designs and sizes, and are fully welded into the work surface.

CLEANING TABLE SYSTEMS WITH MAXIMUM VERSATILITY

The modular design of MediFurn furnishings means cleaning table systems can be created in any conceivable shape and size. They optimally combine high standards of functionality and ergonomic design. Precision manufacturing and smart solutions down to the finest detail guarantee easy cleaning and safety up to hygiene level H2.

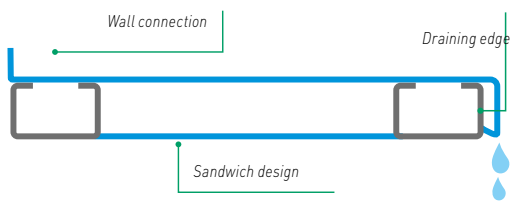

Beaded edging and draining edge

The beaded edging stops liquids dripping from the worktop while the draining edge reduces the risk of liquids penetrating the inside of the cabinet. Continuous lip seals on the doors and runners provide additional protection.

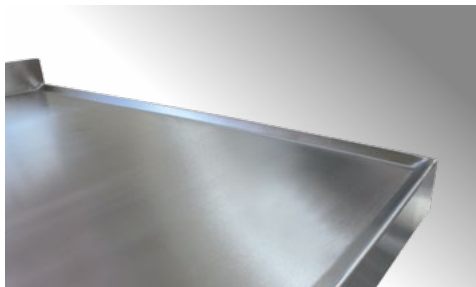

Effective beaded edging: Stops liquids from dripping off the worktop.

Work surface welded on site with fully welded upstand

For extra large, full-length work surfaces, multiple surface elements are welded together during assembly on site. The tabletops are seamlessly welded on site. The fully welded upstands form a secure, hygienic connection with the wall. With the sandwich design, the undersides of the worktops are also sealed to prevent any hidden cavities.



PRACTICAL PROOF

Take a look at how our solutions are used in the projects on site.

Call us for advice:

Michael Voßkübler
Key Account Manager
MediFurn
Tel.: +49 151 6889 4250
M. Vossküehler@hupfer.com



Click here for our reference project at MOC Ahlen

TALL CABINETS AND WALL CABINETS FOR OPTIMAL STORAGE

Cabinets should not only provide plenty of space for safely storing items, they also need to be tidy, versatile and easy to use.

MediFurn tall cabinets and wall cabinets optimally combine all these features. They can be precisely tailored to a wide array of storage items and provide quick and secure access to material and instruments.



Solid shelves and wire shelves can be used to store a variety of items.



Alternatively, **polymer support walls in ISO** format are available for storing modular and sterile supplies baskets, making it even easier to handle items.



HYGIENE
STUFE
H2

HYGIENE
STUFE
H1

HYGIENE
STUFE
HS

Available in various hygiene levels. For more details see page 14

Claddings, inclined tops and flat tops ensure visually tidy connections all round to stop dust from collecting and to make the cabinets easier to clean.



The **instrument cabinet** is specially designed for safely storing medical instruments. It can be easily pulled to provide a perfect overview of everything inside. Holders are available for a many different instruments.

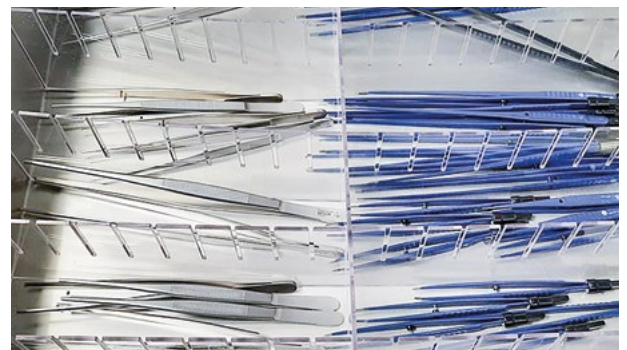

Drawers in a range of sizes can be integrated as required.



Depending on the application, the **cabinet modules** can be equipped with Medidul bays to hold **StU or ISO-standard** sterile supplies baskets and containers.



Pass-through cabinet

This is the perfect barrier between clean and unclean areas in combination with a Känguruh system.

PACKING TABLES FOR EFFICIENCY AND ERGONOMICS

Checking, sorting, cleaning, packaging – packing tables are used for a range of jobs at a single place. This means there are very high requirements for safe, functional and ergonomic technical equipment.

MediFurn packing tables are made completely of premium quality stainless steel and are designed to be easily adapted to the individual needs of employees.

Perfect illumination

- Lighting design based on specific requirements
- LED lighting for high energy efficiency
- Fluorescent tubes with cold light and high luminous intensity
- Illuminance 1000 lx

Height-adjustable tables

- Working height can be adjusted by up to 300 mm at the touch of a button
- Standard basic height of 850 mm, available with a lowest basic height of 750 mm on request
- Digital display for easy adjustment of the required working height
- Side and rear aprons as trap guard for optimum safety at work

PC cabinet

- The PC cabinet with a fully extendable runners has hinged doors with vents for air circulation around computers and other devices that heat up.

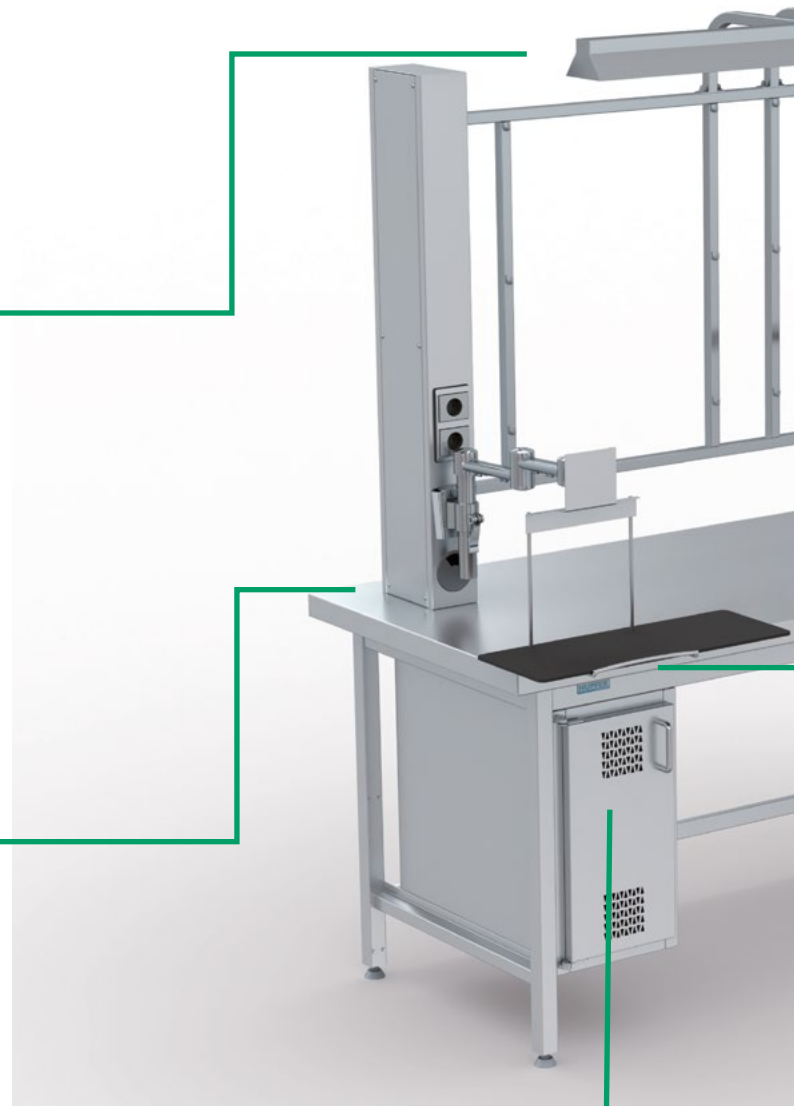

The tables offer maximum flexibility for connection to existing building services and can be adjusted to the ideal working height at the touch of a button. All the technical components are arranged within easy reach. On request, MediFurn packing tables are also available as mobile versions with wheels. The pull-out tabletop is the ideal solution when extra space is required.



■ Removable and reusable cleaning guns are available as an option.

Central utility column

- For protected connection to customer's network, power and compressed air supply
- Available in low version at a height of 110 cm from the edge of the table or in a room-height version with cables routed straight from the ceiling
- Freely configurable connections, accessible at any time via the inspection opening

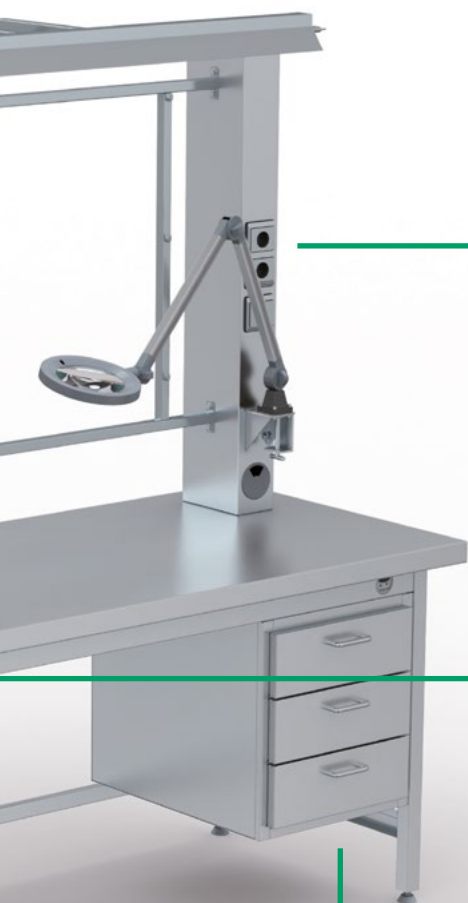

Practical cabling

- Building-side connections are routed and distributed inside the trough under the work surface across almost the entire width
- No tangle of cables on the user side

An optional pull-out table top is the ideal solution for when additional workspace is needed. When not in use, it can be pushed back under the work-top to save space.

Custom-made bases

- Base equipped to meet user needs: Drawer blocks with a range of partitions
- Box and frame drawers for GN containers: fully extendable runners and many other features
- Optional self-retracting function for maximum user convenience
- Alternative: Bases with hinged doors

SINK UNITS

- High load capacity and stability
- Noise insulation for better acoustics
- Perfect hygiene



Sink unit
■ With 2 basins



Sink unit
■ 2 basins
■ 2 pull-out spray taps
■ 2 hinged door cabinets



Sink unit
■ 3 basins
■ 3 pull-out spray taps



LIGHT TABLES

- Allow precise inspection
- Illumination without shadows
- Maximum flexibility
- Optimal hygiene



Light table

- The fully welded light tables are illuminated work tables for checking surgical laundry for holes.



Light table with solid shelf

- Provides maximum additional storage space underneath the table



Mobile light table

- Additional wheels for practical movement, e.g. to clean floor underneath



OUR HYGIENE LEVELS AT A GLANCE

In addition to the usual HS hygiene standard, the bodies of our furnishings are available in the optimised hygienic design types H1 and H2 **in accordance with DIN 18865-9**.

The new models are characterised by a fully welded finish, with corners rounded to various spherical radii. The key benefit of the fully welded design is that there are no cavities which secretions, blood, proteins or other liquids might get into.

This makes thorough cleaning very easy, effectively reducing the spread of dangerous germs. Even hose-cleaning is now possible, because water cannot penetrate the H1 and H2 models.



For **hygiene level H2**, the bases and the side and rear panels of the bodies are fully welded with a spherical radius of around 20 mm on the inside. This extra large radius is ideal for particularly thorough cleaning and significantly reduces the risk of germs. H2 bodies thus also offer maximum safety in places with very high hygienic requirements.



For **hygiene level H1**, the bases and the side and rear panels of the bodies are also fully welded, with a smaller spherical radius of around 3 mm on the inside. H1 bodies are recommended for areas with low to moderate hygiene requirements.



Hygiene level HS is still the standard that is most commonly used. With this body construction, there are still joints between the base, side panels and rear panels, which must be manually wiped with disinfectant. This means HS bodies are only suitable for areas where hygiene is not critical.

TOP QUALITY RIGHT DOWN TO THE SMALLEST DETAIL

The high quality of MediFurn equipment is reflected in its clever design and its many useful details. The modular system with floor frames, base cabinets and tops in range of different sizes and versions is designed to meet the requirements of the customer and the workplace while making optimal use of the available space. And naturally, we can supply a many different technical accessories from our extensive product range.



The quickest fix: plinth with magnetic fastening

The 100 mm high plinth is secured to the floor frame with a magnetic fastening and the joint can be sealed with silicone if necessary. This allows the plinth to be quickly removed for maintenance.



Safe and strong: threaded bolts

All bolts are tightly sealed to prevent cavities and ensure safe cleaning. The base shelves can be easily adjusted without tools.



Easy-to-clean hinges

The low height and large opening angle of the hinges allow easy, unhindered access to the inside of the cabinet. In addition, the hinge can be mounted on the cabinet without using tools.



Easy-to-clean handles

The handles of drawers, pull-outs and cabinet doors are rounded to eliminate corners for easy cleaning.



Safety all round

The continuous seals on runners and doors stop liquids and dust from getting in.



Interested?

[View detailed product information including sizes in our product overview catalogue.](#)

ARE YOU INTERESTED IN OUR PRODUCTS?



You can find a lot more information on our website.

Your Hupfer contact will be happy to advise you.
Contact us now and make an appointment!

*ITM 06/24_SD 06/24 © HUPFER © 2024. All data/dimensions are approximate. Subject to technical changes.
Not to be reproduced in any form, whether in part or in full, without prior permission. Concept and layout: ITM design GmbH, Gescher*

Hupfer Metallwerke GmbH & Co. KG
Dieselstraße 20 · 48653 Coesfeld, Germany
Postfach 14 63 · 48634 Coesfeld, Germany
Tel.: +49 2541 805-0
info@hupfer.com · www.hupfer.com

HUPFER
we make work flow