

Operating Instructions

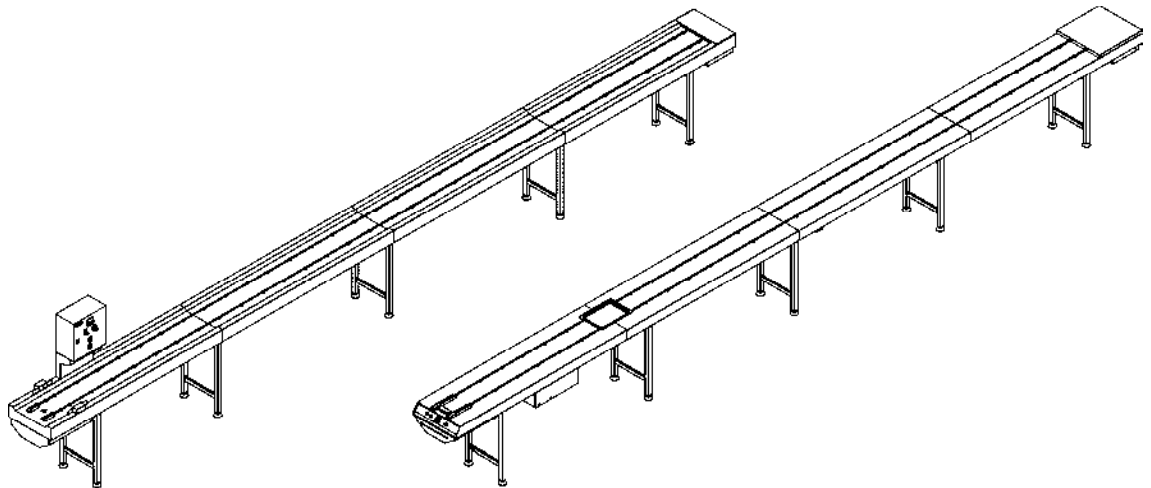

Round Belt Conveyor System

SGR | SPV

1 Introduction

1.1 Appliance Information

Appliance name	Round Belt Conveyor System
Appliance type/s	SGR SPV
Year of manufacture	2014
Manufacturer	HUPFER® Metallwerke GmbH & Co KG Dieselstraße 20 48653 Coesfeld Germany Postfach 1463 48634 Coesfeld Germany ☎ +49 2541 80 50 📠 +49 2541 805 111 www.hupfer.de info@hupfer.de

Read and understand these operating instructions to ensure safe operation and avoid any damage! Ensure that operating staff have been briefed regarding sources of danger and possible incorrect handling.

Subject to modifications

The products covered by these operating instructions have been developed while taking into account market requirements and the latest technology. HUPFER® reserves the right to modify the products and related technical documentation in the interests of technical progress. The data and weights as well as the description of performance and functions assured in the order confirmation as binding are always decisive.

This manual is a translation of the original edition.

Manual edition
4330054_A3

1.2 Table of Contents

1	Introduction	2
1.1	Appliance Information	2
1.2	Table of Contents	3
1.3	List of Abbreviations	5
1.4	Definitions of Terms	6
1.5	Orientation of the Appliance	7
1.6	Notes on Using the Manual	8
1.6.1	Notes on the Manual Structure	8
1.6.2	Notes and their Representation used in all Sections	8
2	Safety Instructions	9
2.1	Introduction	9
2.2	Warning Symbols Used	9
2.3	Safety Instructions for Appliance Safety	10
2.3.1	Special Safety Instructions for Mobile Conveyor Systems	10
2.4	Position of the Emergency Stop Button	11
2.5	Safety Instructions for Transport and Installation	11
2.6	Safety Instructions for Use and Operation	11
2.7	Safety Instructions for Maintenance and Care	12
2.8	Safety Instructions Regarding Troubleshooting	12
2.9	Notes on Specific Hazards	13
3	Description and Technical Data	14
3.1	Performance Description	14
3.2	Proper Use	14
3.3	Improper Use	14
3.4	Appliance Description	15
3.4.1	View of the Crockery Return Belt System (SGR)	15
3.4.2	View of the Food Distribution Belt System (SPV)	16
3.4.3	Equipment and Optional Accessories	16
3.5	Technical Data	18
3.6	Rating Plate	19
4	Transport, Installation, Initial Operation and Taking out of Service	20
4.1	Transport	20
4.2	Assembly	20
4.2.1	Assembling the Segment	21
4.2.2	Assembling the Round Belts	22
4.3	Putting into Operation	25
4.3.1	Connecting the Conveyor System	26
4.3.2	Measures for Putting the Appliance into Operation	26
4.4	Decommissioning, Storage and Recycling	26



5	Operation	28
5.1	Arrangement and Function of the Operating Elements	28
5.2	Operation	29
5.3	Measures at the End of Use	29
6	Troubleshooting and Repair	30
6.1	Safety Measures	30
6.2	Instructions regarding Fault Repair	30
6.3	Fault and Action Table	30
7	Care and Maintenance	32
7.1	Safety Measures	32
7.2	Hygiene Measures	32
7.3	Notes on Care and Maintenance Measures	32
7.3.1	Maintenance	33
7.3.2	Restretch the Round Belt	33
7.4	Special Care Instructions	34
8	Spare Parts and Accessories	35
8.1	Introduction	35
8.2	Spare Parts and Accessories List	35
9	Annex	36
9.1	Monthly Maintenance Checklist	36
9.2	Safety Instruction Protocol	37
9.3	EC Declaration of Conformity	38

1.3 List of Abbreviations

Abbreviation	Definition																																				
BGR	German Employers' Liability Insurance Association rule (<i>Berufsgenossenschaftliche Regel</i>)																																				
BGV	German Employers' Liability Insurance Association regulations (<i>Berufsgenossenschaftliche Vorschrift</i>)																																				
CE	Communauté Européenne European Community																																				
DIN	German Institute for Standardisation, technical regulations and technical specifications																																				
EC	European Community European Community																																				
EN	European Standard (<i>Europäische Norm</i>) Harmonised standard for the EU market																																				
E/V	Spare or wearing part (<i>Ersatz- bzw. Verschleißteil</i>)																																				
HACCP	Hazard Analysis and Critical Control Points Hazard analysis of critical control points																																				
IP	International Protection. The abbreviation IP and a further two-digit index specify the protection class of a housing. The first digit: Protection against ingress of solid foreign objects The second digit: Protection against ingress of water																																				
	<table border="1"> <tbody> <tr> <td>0</td> <td>No protection against contact, no protection against ingress of solid foreign objects</td> <td>0</td> <td>No protection against ingress of water</td> </tr> <tr> <td>1</td> <td>Protection against contact with any large surface of the body such as the hand, protection against ingress of foreign objects $\varnothing > 2.0''$ (50 mm)</td> <td>1</td> <td>Protection against dripping water (vertically falling drops)</td> </tr> <tr> <td>2</td> <td>Protection against contact with the fingers, protection against ingress of foreign objects $\varnothing > 0.5''$ (12 mm)</td> <td>2</td> <td>Protection against dripping water (at any angle up to 15° from the vertical)</td> </tr> <tr> <td>3</td> <td>Protection against contact with tools, wires or similar objects of $\varnothing > 0.1''$ (2.5 mm), protection against foreign objects $\varnothing > 0.1''$ (2.5 mm)</td> <td>3</td> <td>Protection against water drips at any angle up to 60° from the vertical</td> </tr> <tr> <td>4</td> <td>Protection against contact with tools, wires or similar objects of $\varnothing > 0.04''$ (1 mm), protection against foreign objects $\varnothing > 0.04''$ (1 mm)</td> <td>4</td> <td>Protection against water splashing from any direction</td> </tr> <tr> <td>5</td> <td>Protection against contact, protection against dust deposits inside</td> <td>5</td> <td>Protection against water jets (projected by a nozzle) at any angle</td> </tr> <tr> <td>6</td> <td>Complete protection against contact, protection against ingress of dust</td> <td>6</td> <td>Protection against rough sea or strong water jets (flood protection)</td> </tr> <tr> <td></td> <td></td> <td>7</td> <td>Protection against ingress of water during temporary immersion</td> </tr> <tr> <td></td> <td></td> <td>8</td> <td>Protection against pressurised water during continuous immersion</td> </tr> </tbody> </table>	0	No protection against contact, no protection against ingress of solid foreign objects	0	No protection against ingress of water	1	Protection against contact with any large surface of the body such as the hand, protection against ingress of foreign objects $\varnothing > 2.0''$ (50 mm)	1	Protection against dripping water (vertically falling drops)	2	Protection against contact with the fingers, protection against ingress of foreign objects $\varnothing > 0.5''$ (12 mm)	2	Protection against dripping water (at any angle up to 15° from the vertical)	3	Protection against contact with tools, wires or similar objects of $\varnothing > 0.1''$ (2.5 mm), protection against foreign objects $\varnothing > 0.1''$ (2.5 mm)	3	Protection against water drips at any angle up to 60° from the vertical	4	Protection against contact with tools, wires or similar objects of $\varnothing > 0.04''$ (1 mm), protection against foreign objects $\varnothing > 0.04''$ (1 mm)	4	Protection against water splashing from any direction	5	Protection against contact, protection against dust deposits inside	5	Protection against water jets (projected by a nozzle) at any angle	6	Complete protection against contact, protection against ingress of dust	6	Protection against rough sea or strong water jets (flood protection)			7	Protection against ingress of water during temporary immersion			8	Protection against pressurised water during continuous immersion
0	No protection against contact, no protection against ingress of solid foreign objects	0	No protection against ingress of water																																		
1	Protection against contact with any large surface of the body such as the hand, protection against ingress of foreign objects $\varnothing > 2.0''$ (50 mm)	1	Protection against dripping water (vertically falling drops)																																		
2	Protection against contact with the fingers, protection against ingress of foreign objects $\varnothing > 0.5''$ (12 mm)	2	Protection against dripping water (at any angle up to 15° from the vertical)																																		
3	Protection against contact with tools, wires or similar objects of $\varnothing > 0.1''$ (2.5 mm), protection against foreign objects $\varnothing > 0.1''$ (2.5 mm)	3	Protection against water drips at any angle up to 60° from the vertical																																		
4	Protection against contact with tools, wires or similar objects of $\varnothing > 0.04''$ (1 mm), protection against foreign objects $\varnothing > 0.04''$ (1 mm)	4	Protection against water splashing from any direction																																		
5	Protection against contact, protection against dust deposits inside	5	Protection against water jets (projected by a nozzle) at any angle																																		
6	Complete protection against contact, protection against ingress of dust	6	Protection against rough sea or strong water jets (flood protection)																																		
		7	Protection against ingress of water during temporary immersion																																		
		8	Protection against pressurised water during continuous immersion																																		
LED	Light Emitting Diode Light diode																																				
LMHV	Regulation on the hygiene of foodstuffs																																				
RCD	Residual Current Device Residual current device (RCD)																																				
STB	Safety temperature limiter																																				

1.4 Definitions of Terms

Term	Definition
Authorised specialist	An authorised specialist is a specialist that has been trained by the manufacturer, an authorised service dealer or a company assigned by the manufacturer.
Cover	A bell-shaped cover for keeping food warm on plates and dishes.
Cook&Chill Kitchens	"Cook and Chill": Kitchens where warm food is chilled as quickly as possible after being cooked.
Cook&Serve Kitchens	"Cook and Serve": Kitchens where warm food is served immediately after being cooked or kept warm until it is consumed.
Element formation	Also: contact corrosion. Occurs when different noble metals are in close contact with each other. This happens when a corrosive medium is between both metals, such as water or even normal air moisture.
EM field	Electrical, magnetic or electromagnetic field that is defined by its field intensity and phase formation.
EN tray	A European standard tray is a tray in a standard size. EN 1/1 corresponds to 20.9x14.6" (530x370 mm), EN 1/2 corresponds to 14.6x10.4" (370x265 mm).
Specialist	A specialist is a person who can assess work assigned and can recognise possible hazards themselves based on their professional training, skills, experience and knowledge of the respective guidelines.
Gastronorm	Gastronorm is a measurement system used worldwide in places such as food processing plants or large-scale kitchens. The use of standardised sizes makes it possible to exchange food pans. The basic size of the Gastronorm (GN) 1/1 is 20.9x12.8" (530x325 mm). Items are available in different depths.
GN tray	A Gastronorm standard tray is a standard-size tray. GN 1/1 corresponds to 20.9x12.8" (530x325 mm), GN 1/2 corresponds to 12.8x10.4" (325x265 mm).
H1	Hygienic standard (NSF/USDA) for lubricants that are suitable for incidental and technically unavoidable contact with foodstuffs.
HACCP	HACCP is a preventive system that is designed to ensure the safety of foods and consumers.
Lift	A movement, for example a vertical movement of the guide basket from bottom to top.
Check, inspect	Compare with certain conditions and/or characteristics such as damage, leaks, filling levels and heat.
Convection	Physical properties or mass transfer (e.g. heat or cold) through currents in gases and liquids.
Corrosion	The chemical reaction of a metallic material with its surroundings, e.g. rust.
LMHV	German Regulations on the Hygiene of Foodstuffs Regulations regarding hygiene requirements for producing, handling and placing food on the market
Machine safety	The term machine safety refers to all the measures used to avert injury to persons. The basis for machine safety is directives and laws for protecting users of technical devices and systems valid nationally and across the EC.
Passive layer	A non-metallic protective layer on a metallic material that prevents or slows down material corrosion.
Porcelain-Standard	Porcelain-Standard is a measurement system for porcelain plates drafted by HUPFER®. The basic size of Porcelain-Standard (PN) 1/1 is 8.7x6.3" (220x160mm) (1/2 PN conforms to 4.3x6.3" (110x160mm), 1/4 PN conforms to 6.3x3.1" (160x80 mm)). The fitting lids have the following dimensions: 1/1 PN 9x6.6" (228x168mm), 1/2 PN 4.4x6.3" (111x161mm), 1/4 PN 4.4x3.2" (111x81mm).
Verify, test	Compare with certain values such as weight, torque, content or temperature.

Term	Definition
Qualified person, qualified personnel	Qualified personnel are persons who due to their professional training, experience, instruction and their knowledge of relevant standards, guidelines, accident prevention regulations and operating conditions have been authorised by a person responsible for system safety to carry out required activities and can recognise and prevent any potential hazards (definition of specialists according to IEC 364).
Schuko®	The abbreviation of the German term "Protective contact" indicates a system of domestic plugs and sockets equipped with protective earthed contacts used in most of Europe.
Protection class	<p>0 -</p> <p>I </p> <p>II </p> <p>III </p>
Instructed persons	An instructed person is a person who has been instructed on the possible risks resulting from improper behaviour when carrying out an assigned task and regarding the necessary protective equipment and protective measures, and who has been trained for this task, if necessary.
suitable for washing devices	<p>The appliance is suitable for cleaning in an automated cleaning system without restrictions. Following agreement with the manufacturer the cleaning system must achieve a hygienic, constant cleaning and drying result, which is to be approved by a third party (client).</p> <p>The exterior and interior housing are manufactured to a standard guaranteeing hermetic sealing. It is not possible for water jets to ingress into hollow spaces in the appliance. Installed electrical components and electrical wiring are protected by appropriate sealing against any form of penetration by water. Protection class IPX6 (powerful pressurised water) to DIN EN 60529 (VDE 0470) is guaranteed. No water remains or is carried over following the drying process.</p>
cleaning system-resistant	<p>The suitability of the appliance for cleaning in an automated cleaning system is limited. It is possible to achieve a flawless, reproducible cleaning and drying result, but it cannot be guaranteed.</p> <p>The exterior and interior housing are produced to standard specifications. Water ingressing hollow spaces resulting from the design of the appliance can run off without hindrance. Water collection in hollow spaces is avoided. Installed electrical components and electrical wiring are protected by appropriate sealing (for example, labyrinth edges, sealing profiles, cable channels) against any form of penetration by water. Protection class IPX6 (powerful pressurised water) to DIN EN 60529 (VDE 0470) is guaranteed. It is possible that water remains and is carried over following the drying process.</p>
VESKA standard	Trays as per the VESKA standard are items used for distributing food in hospitals, principally in Switzerland; they measure 530x375 mm.

1.5 Orientation of the Appliance

The front

"Front" refers to the side where members of the staff place trays (beginning of the belt).

The rear

"Rear" refers to the side where members of the staff remove trays from the belt. The operating elements of the conveyor system are fitted here (end of the belt).

The right

"Right" refers to the right side of the conveyor system in relation to the conveying direction.

The left

"Left" refers to the left side of the conveyor system in relation to the conveying direction.



1.6 Notes on Using the Manual

1.6.1 Notes on the Manual Structure

This manual is divided into function- and task-focused sections.

1.6.2 Notes and their Representation used in all Sections

The warnings and notes are separated from the other text and particularly marked by corresponding icons. The icon cannot, however, replace the text of the safety instructions. Therefore, always read thoroughly the full text of the safety instructions. The warnings and notes are separated in these operating instructions as follows and categorised by the following danger levels by means of various symbols.

DANGER	Brief description of hazard
	<p>There is an imminent threat to life and physical well-being for the user and / or third parties if instructions are not followed precisely or the circumstances described are not taken into account.</p> <p>The type of hazard is indicated by a symbol and explained in the accompanying text in more detail. The general symbol for danger is used in this example.</p>
WARNING	Brief description of hazard
	<p>There is an indirect threat to life and physical well-being for the user and / or third parties if the instructions are not followed precisely or the circumstances described are not taken into account.</p> <p>The type of hazard is indicated by a symbol and explained in the accompanying text in more detail. The general symbol for danger is used in this example.</p>
ATTENTION	Brief description of hazard
	<p>There is a potential risk of injury or damage to property if the instructions are not followed precisely or the circumstances described are not taken into account.</p> <p>The type of hazard is indicated by a general symbol and explained in the accompanying text in more detail. The general symbol for danger is used in this example.</p>
NOTE	Brief description of additional information
	<p>Attention is pointed to special conditions or additional important information on the topic concerned.</p>
INFO	Short title
	<p>Contains additional information on aspects which make work easier or recommendations on the topic concerned.</p>

2 Safety Instructions

2.1 Introduction

The Safety Instructions section describes the risks associated with the appliance in terms of product liability (according to the EU Machinery Directive).









The safety instructions should warn of hazards and help to avoid damages to persons, the environment and property. Please make sure that you have read and understood all the safety instructions given in this section.

You must comply with the respectively valid national and international Safety at Work Regulations. The manufacturer is responsible for the valid regulations he/she has to provide. He/she must acquaint himself/herself and the operator with the new regulations.

2.2 Warning Symbols Used

Symbols are used in these operating instructions to indicate the dangers that may occur while operating or cleaning the appliance. In both cases, the symbol provides information on the type and circumstances of hazards.

The following symbols may be used:

	General hazard area
	Hazardous electrical voltage
	Risk of hand injuries caused by belt drive
	Risk of hand injuries
	Risk of crushing
	Hazard caused by hot surfaces
	Switching prohibited
	Wear hand protection
	Read and observe the operating instructions

2.3 Safety Instructions for Appliance Safety

The appliance is operated safely if it is used correctly and carefully. Negligent handling of the appliance can lead to a threat to life and physical well-being for the user and / or third parties as well as hazards for the appliance itself and the operator's other property.

The following points are to be observed to ensure the appliance safety:

- The appliance may only be operated as intended, when it is in perfect condition with regards to technical standards, with awareness of safety and hazards and in accordance with the operating instructions.
- All operating and actuating elements must be in a perfect and fail-safe condition with regards to technical standards.
- Only operate the conveyor system when all the safety devices or emergency stop devices are available and function properly. There should be easy access to the emergency stop button. Do not remove safety devices.
- Comply with the safety instructions and hazard warnings on the conveyor system and make sure they are easy-to-read.
- Before putting the appliance into operation, the appliance must be checked for external visible damage and defects. In case of damage, immediately inform the competent bodies and switch off the conveyor system.
- Setting up, installation, dismantling, startup, operating, maintenance and overhaul are only to be carried out by trained operating staff.
- Modifications or retrofits to the equipment are only permitted after consultation with the manufacturer and upon receipt of their consent in writing.
- Stationary conveyor systems are designed for permanent installation.

2.3.1 Special Safety Instructions for Mobile Conveyor Systems

- The conveyor systems are designed for transport by hand only. It is not permitted to use a machine of any type to move the appliance.
- Conveyor systems can start moving on their own and randomly if the casters are not applied.
- Switch off the conveyor system, pull out the mains plug and put it on the belt before transporting it.
- Never pull the mains plug out of the socket by the lead.
- Before moving the conveyor system, release the locking brakes. Moving the appliance with the applied locking brakes can damage the chassis!
- Do not move the appliance over inclined surfaces or stairs. When approaching walls and moving round obstacles always pay attention to persons in the way.
- When transporting the conveyor system, do not move it faster than a walking pace. It is difficult to brake and steer heavily laden appliances. If necessary, ask for assistance when transporting the appliance.
- When moving the conveyor system, make sure that the appliance will not tip over due to outside influences or inattention. If, nevertheless, it tips over never try to catch the conveyor system.
- Secure the conveyor system against rolling away before putting it into operation.
- Do not stop the appliance on sloping floors. Before placing the appliance in position make sure that the floors are level and even and the conveyor system is level.

2.4 Position of the Emergency Stop Button

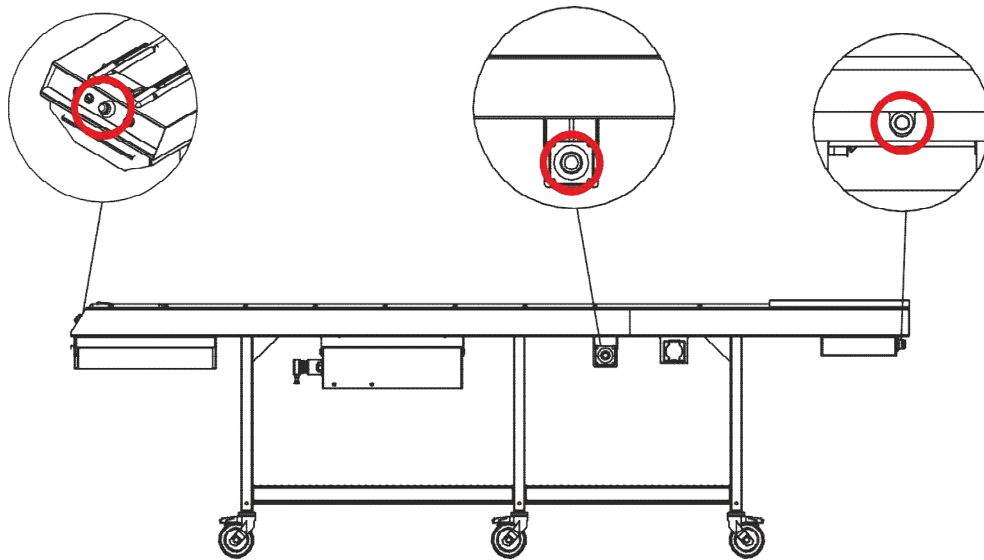

Figure 1 Position of the Emergency Stop button (option)

2.5 Safety Instructions for Transport and Installation

The following aspects are to be taken into account when transporting the conveyor system:

- When loading, use only hoists and load lifting devices approved for the weight of the parts to be lifted.
- Heavy individual parts and larger assemblies must be attached and secured to hoists in such a way that they do not cause any hazards.
- Slings must be attached to the lifting eyes of the conveyor system in such a way that any hazards caused by falling loads are prevented.
- Only use transport vehicles that are approved to carry the weight of the conveyor system.
- Parts that have possibly been dismantled prior transport must be fitted back and fastened before putting the appliance into operation.
- Even in case of a minor relocation switch off the conveyor system at the mains or disconnect it from any power supply.
- Do not put a defective appliance into operation under any circumstances and inform the supplier immediately in such a case.

2.6 Safety Instructions for Use and Operation

The following points shall be observed when using and operating the appliance:

- Staff is to be instructed in the use and operation of the conveyor system before it is started.
- Loose items of clothing (e.g. scarf or tie) and jewellery are not to be worn when working on the conveyor system. Otherwise there is the risk of being pulling in by rotating machinery parts.
- Unimpeded access to the Emergency Stop Buttons must be on hand at all times.
- Make sure that nobody is exposed to a hazard as a result of the activation of the conveyor system before switching on the appliance.

2.7 Safety Instructions for Maintenance and Care

The following points shall be observed when carrying out any maintenance operations:

- Take the conveyor system out of operation, switch it off and secure against unauthorised reactivation before performing maintenance or troubleshooting operations. The appliance must be switched off at the mains and secured against reactivation when working on the electrical system.
- Only persons with qualifications and knowledge of electrical engineering may perform maintenance and repair work on electrical devices.
- If maintenance or repair work at live parts is required, a second person must be involved at all times.
- The maintenance and care intervals specified in the operating instructions must be observed.
- Before proceeding with maintenance and repair work close the maintenance area and the access to the working area for unauthorised persons. If necessary, place an indication sign that draws attention to the running maintenance and repair work.
- Observe the valid product safety regulations for the product when handling oils, greases and other chemical substances.
- Lubricants must be compatible with foodstuffs (e.g. edible oil).
- Carry out all the checks and inspections of the appliance on a regular basis. Remedy deficiencies such as loose screw connections, melted or damaged leads immediately.
- Fit the dismantled safety devices back to the appliance and check them for proper functionality after completing maintenance and repair work.
- Cleaning instructions must be strictly observed for reasons of hygiene.
- Never clean the running conveyor system.
- Do not clean the conveyor system with steam-jet or high-pressure cleaners.
- Take the conveyor system out of operation and switch it off at the mains in any area where steam-jet or high-pressure cleaners are to be used.

2.8 Safety Instructions Regarding Troubleshooting

The following aspects must be taken into account when carrying out any troubleshooting work:

- The local Accident Prevention Regulations in force must be observed.
- Take the conveyor system out of operation, switch it off and secure against unauthorised reactivation before performing maintenance or troubleshooting operations. The appliance must be switched off at the mains and secured against reactivation when working on the electrical system.
- Observe the valid product safety regulations for the product when handling oils, greases and other chemical substances.
- Wear suitable protective clothing when carrying out any repair work.
- Only authorised specialists may repair any faults or malfunctions.
- Tighten the loosened screw connections and fit the safety devices back to the appliance if dismantled, and test their proper functioning after completing the repair work.
- Defective components should be replaced with original parts only.

2.9 Notes on Specific Hazards

Electric power

- All work on the electrical installations should only be carried out by a qualified electrician, or by authorised specialists under the supervision and monitoring of a qualified electrician according to the applicable electro-technical regulations.
- The appliances on which inspection, maintenance and fault repairs are performed must be disconnected from the power supply and secured against reactivation when power is not required for such work. This may only be carried out by a qualified electrician.

3 Description and Technical Data

3.1 Performance Description

The conveyor system is designed to convey trays loaded with crockery. The conveyor system conveys the trays to the following work step. Depending on the type used, the conveying system conveys either clean trays loaded with portioned meals or trays containing dirty crockery.

The crockery return belt system (SGR) is used mainly to hold up Gastronorm and Euronorm trays and to clear away continuously and quickly trays with dirty crockery, cutlery, glasses and napkins. Members of the operating staff clear away the trays loaded with dirty crockery items that are conveyed to the washing area.

The food distribution belt system (SPV) is used mainly to hold up Gastronorm and Euronorm trays and to load continuously and quickly trays with crockery, cutlery, glasses and napkins. Serving devices and operating staff that stays at the conveyor system load trays and serve portions on crockery items. To serve meals up to the guest area, you can use other peripheral devices at the end of the belt.

Thanks to the modular design and the wide number of standard components, the conveyor system can be perfectly suited to any premises. Peripheral appliances and optional accessories can be added in order to substantially streamline operations. Components suitable for use with foodstuffs and easy-to-clean construction ensure the highest hygienic standard.

3.2 Proper Use

The conveyor system is mainly designed to hold up Gastronorm and Euronorm trays. Any other use is not intended.

The crockery return belt system (SGR) is used to hold up and to convey trays with dirty crockery, cutlery, glasses and napkins.

The food distribution belt system (SPV) is used to hold up and to convey trays with portioned meals, clean crockery, cutlery, glasses and napkins.

Proper use includes observing specified procedures, compliance with the technical specifications and use of supplied or optional original accessories.

Any other use of the appliance is considered as unintended use.

3.3 Improper Use

Any other use, especially loading the conveyor system with the other loads than those specified, is not permitted.

In particular, transport of materials hazardous to foodstuffs is considered as unintended use.

Do not transport heavy and sharp-edged items on the conveyor system. It is not permitted to convey stacked crockery items.

Do not allow people to sit or store objects on the conveyor system. Transport of people is not permitted.

It is not permitted to modify or retrofit the conveyor system. Such modifications can pose safety hazard and are considered as unintended.

The manufacturer and suppliers are not liable for any consequential damage resulting from unintended use. No liability is assumed and no warranty claims can be submitted for damages caused by improper use.

3.4 Appliance Description

3.4.1 View of the Crockery Return Belt System (SGR)

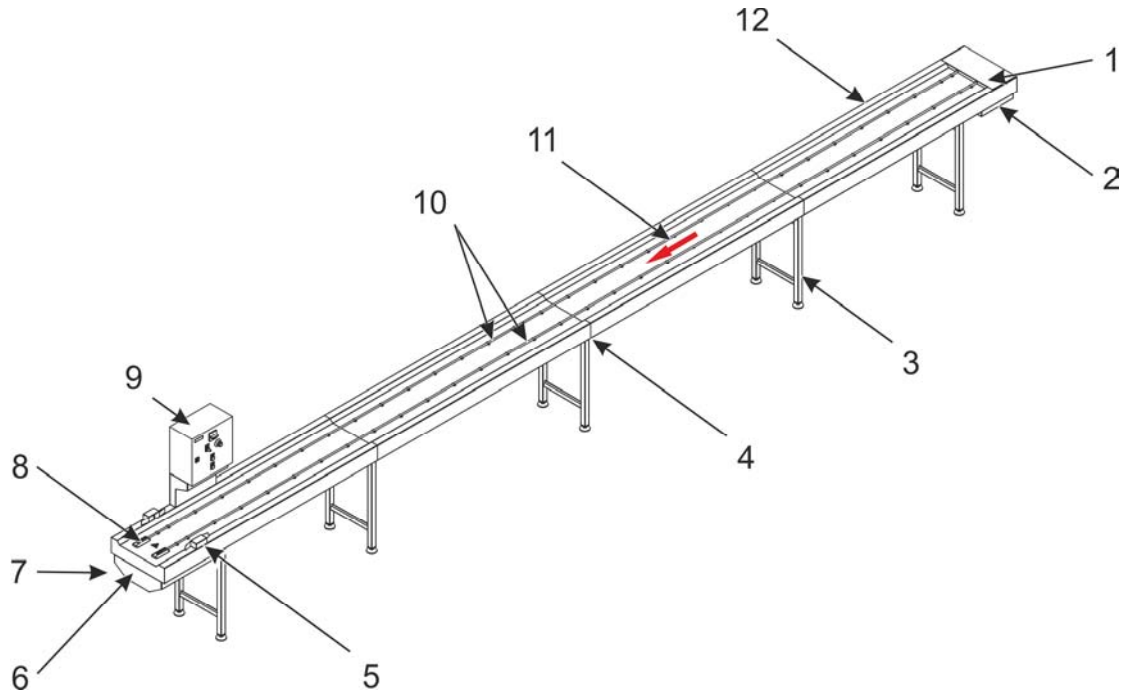

Figure 2 View of the appliance SGR

- | | | | |
|---|---|----|---------------------------------|
| 1 | Beginning of the belt | 7 | End of the belt |
| 2 | Deflection element with conveyor roller | 8 | Finger protection |
| 3 | Belt system leg | 9 | Control with operating elements |
| 4 | Connector | 10 | Round belt |
| 5 | Light barrier | 11 | Conveying direction |
| 6 | Drive component | 12 | Belt casing |

3.4.2 View of the Food Distribution Belt System (SPV)

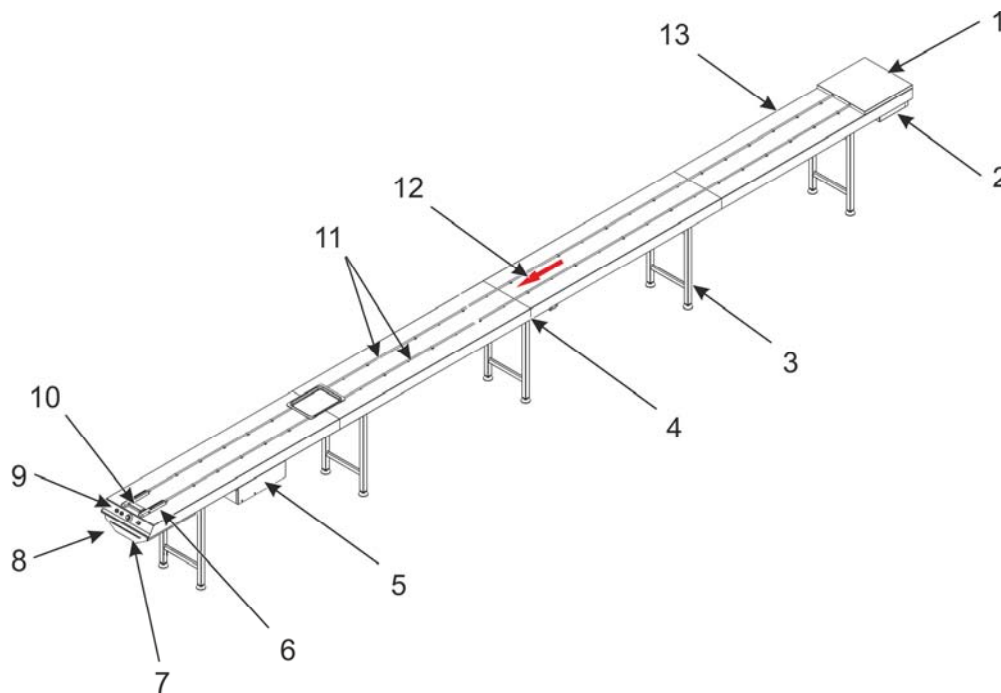

Figure 3 View of the appliance SPV

1	Beginning of the belt	8	End of the belt
2	Deflection element with conveyor roller	9	Operating elements
3	Belt system leg	10	Limit switch
4	Connector with holder	11	Round belt
5	Control	12	Conveying direction
6	Finger protection	13	Belt casing
7	Drive component		

3.4.3 Equipment and Optional Accessories

You can install and fit the conveyor system with optional accessories in various ways:

- **Types of installation (SGR and SPV)**
The standing alone design of the conveyor system is mounted on stands. A combination of wall and base installation is possible.
A mobile design includes 2 swivel casters per belt system leg. All the swivel casters have total brakes for safety reason.
- **Plastic shelves in the base (SGR and SPV)**
The plastic shelves are designed as storage shelves in the base. Put the elements on to the long rails fitted in the base of the conveyor belt. The shelves can be used even at maximum load (up to 100 kg/m) for longer time at the temperature between -30°C and +70°C. The plastic shelves can be easily removed to clean the appliance.
- **Mechanical limit rocker switch (SGR and SPV)**
The pivotable limit rocker switch is installed on the surface of the structure at the end of the belt between the finger protection elements. When loads are applied, the limit rocker switch is pressed down and an electrical signal is created which stops the belt movement. The switch mechanism is protected on all sides against ingress of liquids and dirt particles. Cleaning is only to be done when the belt is switched off. After releasing the limit rocker switch the belt will start moving automatically.
- **Photo-electric limit switch (SGR and SPV)**
The photo-electric limit switch is installed in the frame surface at the end of the belt between the round belts. If a non-transparent item, e.g. a tray, moves across the photo cell, a signal is triggered which stops the belt movements. The belt automatically starts to run again once the photo cell is released.

- **Foot switch (SPV only)**
The foot switch allows to start and stop the conveyor belt. It is used in addition to the operating elements on the control panel.
- **Patient card drawer (SPV only)**
The patient card drawer holds up patient cards and can be removed quickly and completely without any tools. It is fitted under the conveyor belt at the beginning of the belt system. Do not exceed the maximum load of 25 kg.
- **Rotary table (SPV only)**
Use the rotary table that is fitted at the beginning of the belt at about 9.8" (250 mm) from the front side to keep your records or other information. The rotary table and the support tube rotate independently of each other. The rotary table may only be moved when there are no objects on its surface and there are no people around it. Do not exceed the maximum load of about 5 kg. The rotary table is delivered disassembled. To assemble the rotary table, insert the support tube into the plastic part.
- **Hinged board (SPV only)**
The hinged board is an additional storing shelf and is fitted flush at the end of the belt. You can fold up the board lifting it slightly up and raising it to an angle of 90°. There should be no objects on the board when folding it down. Do not exceed the maximum load of about 10 kg, otherwise there is a risk of damage to materials.
- **Curved elements (SGR)**
Curved elements are for connecting straight segments. They are available in standard 45° and 90° angles. Acute angles in excess of 135° are provided with their own drive. These curved elements feature a single belt running centrally across guide rollers. The trays are supported by plastic sliding rails in continuation of the straight belt. Appropriately adapted stainless steel tray guiding rails undertake guidance at the sides.
- **Tray guiding rails for bends (SGR only)**
Tray guiding rails are required for guiding the trays correctly in bends. Transporting trays in bends without tray guiding rails will not work as they may get turned round, twisted and jammed. A set consists of plastic blocks, stainless steel tray guiding rails and fastening material. The plastic blocks are bolted onto the structure and are for holding the tray guiding rails. As the tray guiding rails are inserted in blocks, they ensure a high degree of stability. The tray guiding rails in the sets are appropriately bent to fit.
- **Light barrier (SGR only)**
The light barrier prevents the further movement of loaded trays beyond the end of the belt. Place the light barrier at the middle, about 350 mm from the end of the belt.
Light barrier and reflector are mounted at the end of the belt as a height restrictor (crockery detector) and fitted in stainless steel covers. They must be fastened facing each other and flush on the bar of the edge of the well. The optics are adjusted on the basis of consultation. The minimum and maximum height above the edge is 5 mm and 20 mm respectively.
- **Sorting bridges (SGR only)**
The sorting bridge is used for safe storage on the opposite belt casing. You can fold it up by lifting it slightly up and raising it to an angle of 90°. The unfolded sorting bridge is flush with the belt casing. The hinged design without a chute but with a sound absorbing panel attached at the bottom can be fitted on the belt upon agreement. The maximum load of the sorting bridge is 25 kg.
- **Tilt switch (SGR only)**
The tilt switch prevents any further movement of loaded trays beyond the end of the belt. With automatic stacking, a tilt switch as a height restrictor or crockery detector is fitted at the end of the belt in the sorting area.
The height restrictor can be universally adjusted to all the usual crockery heights. The overall height is 190 mm +/- 15 mm. The tilt switch is mounted on the belt structure in such a way that the front edge is positioned at a distance of 250 mm from the edge of the belt. This allows the belt to be positioned directly against a wall, which saves space. The tilt switch is always to be positioned in front of the switch box. Otherwise, bottles on the tray would not be recognized in time and might collide with the underside of the switch box.
- **Magnetic cutlery pickup device (SGR only)**
The magnetic cutlery pickup device lifts, transfers and ejects magnetically detectable cutlery items into the corresponding collecting carriages. The device with magnet and internal conveyor belt is horizontally mounted above the conveyor belt. All other items must not be caught by the cutlery pickup device and must be removed before the pickup process is initiated.
- **Queue-locked circuit (SGR only)**
The queue-locked circuit is needed for continuous tray removal. The round belt conveyor runs at a

constant speed in the tray hand-in area of the guest room. Behind the hand-in section there is a band segment with separate motor and round belt. When a tray leaves the hand-in area, the belt moves on by a little over one tray length. The following belt (behind the hand-in area) is thus loaded with a tray in cycles. A photo-electric switch in the casing acts as the signaller. If required, the queue-clocked circuit can be switched off. With the standard operating elements, the selector switch is arranged on the switch box.

- Input area with collecting pan (SGR only)
The collecting pan collects spilled liquids in the input area and therefore prevents contamination of the round belts. No tool is needed to remove the perforated plates for cleaning the collecting pan.
- Intermediate segment (SGR only)
The intermediate segment for the sorting area with one-sided structure taper, smooth casing surface and centre base is needed for more comfortable working. Thanks to the structure taper, work can be carried out right next to the belt casing and objects can be easily handed over to the other side.

3.5 Technical Data

SGR SPV	Value	Dim.	Note
Structure length (min. /max.)	118.1 - 511.8 (3000 - 13000)	in (mm)	The structure length is variable.
Conveyor length (min. /max.)	100.4 - 494.1 (2550 - 12550)	in (mm)	The real structure length is calculated from the structure length minus 9.8" (250 mm) at the input area and 9.8" (250 mm) at the output area.
Width	19.7 (500)	in (mm)	
Total height	35.4 (900)	in (mm)	
Weight	approx. 33.1 (approx. 15)	lbs/ft (kg/m)	plus 13.6 lbs (30 kg) per conveyor system
Number of legs	3 to 6	Pc.	depending on the length of the conveyor system
Diameter of round belt	0.47 (12)	in (mm)	
Distance between round belts	7.1 (180)	in (mm)	
Motor power	0.12	kW	Bevelled gear drive motor with frequency converter fitted outside (FUG)
Protection class of motor	IP 55		Thermal class F, protection against overheating by thermal contact switch
Speed range	4 to 20	m/min	continuous adjustment
Protection class of switch cabinet	IP 65		
Electrical connection	400	V	3 PH N PE 50 Hz
Basic design			Without sockets. Basic version without FI (RCD) upstream installation by the operator may be required depending on official local power supplier regulations
Types of sockets	230 230 400 400	V Schuko V CEE V CEE 16 A V CEE 32 A	
Power consumption (without sockets)	0.12	kW	One motor plus power supply 0.4 kW. The total power of the belt systems without sockets depends on the type and number of consumers. Basically, 3.6 kW per socket, but depending on the cross section and the protection of the supply line taking into consideration the load diversity factor.
Operating and ambient conditions	+41 to +131 (+5 to +55)	°F (°C)	

You can find the corresponding certification marks on our homepage at www.hupfer.de.

3.6 Rating Plate

The rating plate of the conveyor system is fitted on the inner side of the door of the switch cabinet of the conveyor system.

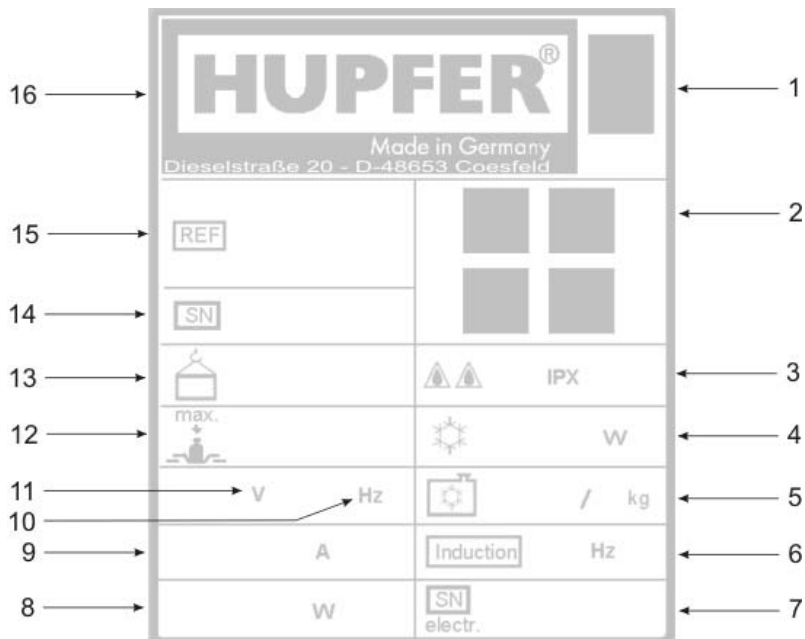

Figure 4 Rating plate

- | | | | |
|---|----------------------------|----|----------------------------|
| 1 | Disposal of old appliances | 9 | Nominal current |
| 2 | Certification mark | 10 | Frequency |
| 3 | Protection class | 11 | Nominal voltage |
| 4 | Refrigeration capacity | 12 | Payload |
| 5 | Refrigerant | 13 | Tare weight |
| 6 | Induction frequency | 14 | Serial number/Order number |
| 7 | Electrical serial number | 15 | Item and brief description |
| 8 | Electric power | 16 | Manufacturer |

4 Transport, Installation, Initial Operation and Taking out of Service

4.1 Transport

The delivered conveyor system with the length of up to 6 m is completely assembled, wired and set so that it is ready for operation.

Conveyor systems with a length of more than 6 m will be delivered segments that have to be assembled.

When loading, use only hoists and load lifting devices approved for the weight of the conveyor system. Only transport vehicles that are approved for the weight of the appliance may be used.

The scope of delivery is specified in the shipping documents in accordance with the valid purchase agreement and included with the delivery item.

4.2 Assembly

DANGER

Hazardous electrical voltage



Electrical current can pose a considerable threat to life and physical well-being and may lead to injuries.

Only an electrician or instructed staff under the guidance and supervision of an electrician may work on electrical systems or operational equipment; they must comply with the electrical industry rules while doing so.

DANGER

Defective emergency stop



In case of fault, e.g. from defective fuses, the drives may continue to run even after the emergency stop has been pressed.

ATTENTION

Injury to persons



Only two people are to carry out mounting the segments and the round belts. Wear protective goggles and safety gloves when putting down and welding the round belt.

INFO

Conveyor systems longer than 6 m

The following section only applies to conveyor systems longer than 6 m which need not be delivered and mounted as a unit.



Check the premises before setting up the conveyor system. Flaws can be detected and improved at an early stage. Observe the following points:

- The floors in the premises where the appliance is to be set up must be level and correspond to the required load-bearing capacity of 196 N/m² (20 kg/m²).
- Electrical connections for the conveyor system must be in place as agreed.
- We do not recommend attaching the conveyor system to the floor of the premises with plugs because of the moisture barrier layer that exists in the most cases.

The user of the conveyor system must take the following measures beforehand to ensure the safety of the operating staff:

- Specify the field of application and draw up corresponding safety instructions.
- Instruct the operating staff in safety.
- Give the operating staff training.
- Mark hazardous areas.

4.2.1 Assembling the Segment

ATTENTION	Injury to persons and/or damage to property
	Parts of the conveyor system may topple over during assembly and cause injuries and damage. The segments should always be mounted by 2 people. Get some help, if need be.
ATTENTION	Damage to property
	Do not place the segments onto the floor with the surface facing down, since they can get scratched or damaged. Use a suitable piece of material to place the segments.
INFO	Disposal of packing material
	The packing consists of recyclable materials and can be disposed of accordingly. The different materials should be separated and disposed of in an environmentally friendly manner. The local agencies responsible for disposal must be contacted regarding removal

Proceed as follows when mounting the segments of the conveyor system:

- Remove the segments from the transport packaging and arrange in the position envisaged.
- When assembling begin with the end of the belt. For this purpose, place the first segment on the marked position.
- Screw the segment under the next part of the belt. When doing this, the first person holds the segment while the second person is pushing the next part of the belt on to the connector of the segment the first person is holding.
- Assemble the segments in such a way that they are flush edge to edge. Ensure that the spacers are in the correct position (between the belt and the connecting plate with the larger bore hole facing the belt). Preload both plates with a hammer and a punch, then fasten all nuts with a maximum torque of 20 Nm.
- Continue with the assembly as described above.
- Check again the inclination and align the conveyor system on the screw feet horizontally with the spirit level until it is level. Normally, the height is 900 mm.

4.2.2 Assembling the Round Belts

ATTENTION	Risk of injury from snapping round belts
	<p>Tensioning may cause the round belt to snap and shoot upwards.</p> <p>Work together with another person. Hold the ends of the round belt as near as possible to the point of connection. Wear protective goggles and safety gloves during the entire assembly procedure.</p>
NOTE	Required tools
	<p>Fitting and welding the round belts is only to be done with the HUPFER® tool which is provided. The welding and tightening set from HUPFER® is included in delivery for assembly purposes.</p> <p>The welding and tightening set consists of the jockey for tightening the round belts, welding tongs for keeping the round belt ends together, the welding iron for welding together the round belts and the mitre cutter.</p>
NOTE	Smooth round belts
	<p>Only smoothly mounted round belts ensure that the trays are reliably and properly transported on the conveyor.</p> <p>Make sure that the round belts do not get twisted when carrying out the operation.</p>

Step 1: Fitting the round belts

Proceed as follows to fit the round belt:

- Keep hold of one end of the round belt, unravel it from the drum and cut to the required length.
- Remove the cover plate at the beginning of the belt system and guide the round belt across the aluminium disk downwards through the belt casing and across the conveyor roller.
- Guide the round belt to the end of the belt system and upwards over the conveyor roller and aluminium disk through the belt casing. The two ends of the round belt are now opposite each other on the surface of the structure.

Step 2: Stretching the round belts

ATTENTION	Risk of injury from snapping round belts
	<p>Tensioning may cause the round belt to snap and shoot upwards.</p> <p>Work together with another person. Hold the ends of the round belt as near as possible to the point of connection. Wear protective goggles and safety gloves during the entire assembly procedure.</p>
NOTE	Operating instructions - Jockey
	<p>The jockey is needed to tension the round belts. The operating instructions of Greifzug GmbH are enclosed with the appliance.</p> <p>Read through the operating instructions before beginning with the tensioning operation. Pay particular attention here to the sections on 'Safety instructions', 'Description of the appliance' and 'Appliance use'.</p>

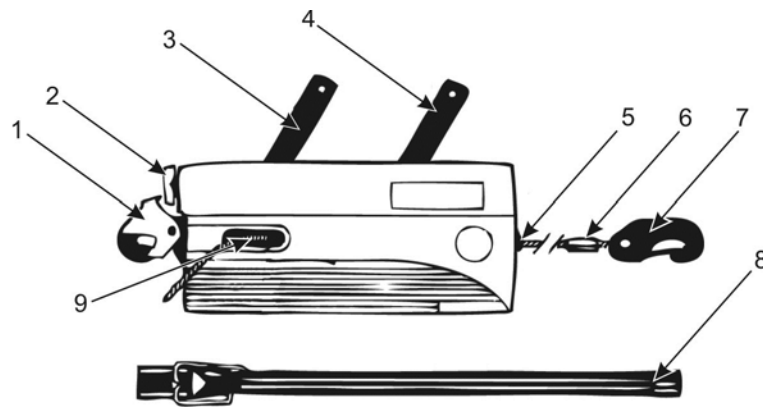

Figure 5 View of the appliance SPV

- | | | | |
|---|---------------------------------|---|---------------------------------|
| 1 | Appliance hook with safety flap | 6 | Traction cable |
| 2 | Releaser | 7 | Load hook with retaining spring |
| 3 | Feed lever | 8 | Lever bar |
| 4 | Return motion lever | 9 | Cable outlet |
| 5 | Cable inlet | | |

Proceed as follows to tension the round belt:

- Take the jockey out of the package and place it upright on the structure surface.
- Mount the enclosed traction cables at the appliance hook with safety flap (1) and at the load hook with retaining spring (7) of the jockey.
- Place the traction cables (6) onto the structure surface parallel to the round belt.
- Fix the round belt with the wire stretchers at the other ends of the traction cables. In doing so, compress the jaws to prevent any slipping out.
- During the whole tensioning operation ensure that the round belt is held by the jaws of the wire stretchers.
- To tension the traction cable (6), attach the lever bar (8) onto the feed lever (3) so that the retaining spring snaps into place in the lever hole. Tension the traction cable by levering uniformly from stop to stop until the two ends of the round belts overlap by some 10 to 15 mm.

Step 3: Heating the welding iron

WARNING

Hot surface



To connect the two round belt ends, the material needs to be melted with the welding mirror of the welding iron. In so doing, the welding mirror can reach temperatures in excess of 482 °F (250°C). There is a risk of scalding on coming into contact with the surface.

Avoid any direct contact with the welding mirror during the operating period and the heating/cooling phases.

INFO

Heating the welding iron

To cut down on the time needed for the work, heating-up can be done before tensioning.

- Place the welding iron on a non-combustible base and heat up for some 8 minutes.

Step 4: Attach the welding tongs

NOTE	Required tools
Welding tongs are required for all further steps in order for the round belts to be tensioned precisely and guided correctly.	

- Undo the limb screws of the welding tongs and open the limbs.
- Insert the round belts into the welding tongs. During insertion, ensure that there is a gap of approx. 0.10 to 0.12" (2.5 to 3.0 mm) between the two round belts, which is able to accommodate the welding mirror of the welding iron.
- Close the limbs of the welding tongs and fix them with the 4 limb screws.
- Slightly press together the hand grips of the welding tongs and check whether the two round belt ends can be flush-closed.

Step 5: Welding the round belts

Proceed as follows to weld the round belt:

- Insert the hot welding mirror of the welding iron into the gap between the two round weld ends.
- Slightly press together the hand grips of the welding tongs. The hot welding mirror causes the material to melt and a bead of liquefied plastic arises at the round belt ends.
- Move the welding iron slightly up and down. Release the hand grips of the welding tongs should bubbles clearly form on the bead.
- Open the welding tongs, remove the welding iron and place on a non-inflammable base.

NOTE	Removing the welding iron
The liquefied plastic of the round belts (bead) is not to be extracted with the filler.	

- Then firmly press together the hand grips on the welding tongs and screw down the side clamp screw. Follow this up by releasing the hand grips of the welding tongs.
- Leave the welding tongs in this condition for 5 to 8 minutes until the round belt has cooled.
- Check at the bead to see if the round belt has completely cooled down.

ATTENTION	Risk of injury from snapping round belts
	Welding which is not properly undertaken may result in the round belt snapping and shooting upwards.
	Slowly remove the welding tongs and jockey. Wear protective goggles and safety gloves during the entire operation.

- Undo the screws of the welding tongs and remove them.
- Slacken the wire stretchers and remove the jockey.

Step 5: Cleaning the welding iron

WARNING

Hot surface



The welding mirror can reach temperatures in excess of 482°F (250°C) during the operating and heating/cooling phases. There is a risk of scolding on coming into contact with the surface.

Let the welding iron cool down for a time before starting any cleaning.

NOTE

Cleaning the welding mirror

To avoid any damage, the welding mirror is to be cleaned when warm. Cleaning it when cold may result in damage to the coating.

- Disconnect the welding iron from the mains supply.
- Use a cloth to wipe the cooled yet still warm welding mirror until all contaminations have been removed.
- Then place the welding iron on a non-inflammable base to cool down completely.

Step 6: Final work

Following the welding procedure, the welding point of the round belt must be processed further and its stability must be confirmed.

- Use a sharp knife to gently cut off the bead on the round belts.
- Test the resilience of the weld seam by bending it by 180° several times.
- Check the tension of the round belt.

NOTE

Tensioning the round belts

Insufficient tension may lead to an uneven speed of the conveyor belt, racing of the drive wheels and grinding noises. If this is the case, the round belts must be re-tensioned.

- Withdraw the protective sheet from the belt casing once the entire procedure is over.

Assembly of the conveyor system is now concluded.

4.3 Putting into Operation

DANGER

Hazardous electrical voltage



Electrical current can pose a considerable threat to life and physical well-being and may lead to injuries.

Only an electrician or instructed staff under the guidance and supervision of an electrician may work on electrical systems or operational equipment; they must comply with the electrical industry rules while doing so.

ATTENTION

Damage to property and injuries to persons



Damaged machinery parts and safety equipment of the conveyor system may result in damage and injuries.

Before each and every operation, check the conveyor system for any external damage and faults - particularly at the safety equipment. Any defects must be reported to the competent bodies immediately. You might have to immobilize the conveyor system.

4.3.1 Connecting the Conveyor System

In some countries, the technical specifications of the power mains may deviate from those provided in these operating instructions. Connection data of the conveyor system (details on the rating plate) must be compared with the connection conditions of the mains supply at the location involved.

The following points are to be observed when connecting the conveyor system:

- Have the power supply installed and the conveyor system grounded in a professional manner.

NOTE	Residual current circuit-breaker
	No residual current circuit-breakers FI (RCD) for the possibly fitted sockets at the belt are installed as standard in the belt control system. However, the local power supplier regulations may make it necessary for the operator of a conveyor system to install residual current circuit-breakers FI (RCD).

- Connect the connecting lead with the distributor of the conveyor system.
- Connect control system/distribution.
- Connect the three-phase motor so that it rotates in a specified direction.
- Protect power supply cables of the conveyor system against exposure to moisture.
- In case of unintended reactivation, stop the appliance by using the control system.

4.3.2 Measures for Putting the Appliance into Operation

There should be no loads on the system while putting it into operation.

The following putting-into-operation points must be examined to ensure safety at the conveyor system:

- All screw connections are fitted at the conveyor system and the protective equipment properly installed.
- No unusual running noises of the round belts or at the drive are present.
- There are no foreign objects at/on the conveyor system, light barrier or limit switches.
- The Emergency Stop button is unlocked.
- The potentiometer is set.

The conveyor system may be put into operation once its correct functioning has been ensured.

4.4 Decommissioning, Storage and Recycling

Proceed as follows to take the conveyor system out of operation:

- Take the conveyor system out of operation and secure it against unauthorised reactivation.
- Switch off the conveyor system and the motor at the mains.

The conveyor system must be kept in a dry, frost-free environment when placed in temporary storage. The conveyor system must be kept covered with a suitable covering material to be protected against dust ingress.

The appliance kept in the storage location must be checked for damage and corrosion every 6 months.

Before the appliance is taken back into operation, it must be clean and dry.

NOTE	Condensation
	Ensure that there is sufficient ventilation and no major variations in temperature in the storage location, so that condensation is prevented from forming.

To dismantle the conveyor system, proceed as follows:

- Take the conveyor system out of operation and secure it against unauthorised reactivation.
- Switch off the conveyor system, the control and the motor at the mains.
- Disconnect the round belt with a knife or pliers and remove.
- Dismantle the control and operating elements.
- Dismantle the conveyor system starting with the first segment at the beginning of the belt system.
- Dismantle all segments up to the end of the belt system.
- Clean all the machine parts to remove used lubricants.
- Remove all seals from the bearings.
- Separate all the plastic, electronics and metal parts from each other.

If the conveyor system is required to be recycled, all the operating and auxiliary materials must be disposed of in an environmentally compatible manner. Recyclable materials must be properly separated and disposed of in an environmentally compatible manner in accordance with local Waste Disposal Regulations. The local agencies responsible for disposal must be contacted regarding removal. Separate the reusable materials of the appliance (casters and plastic parts) before disposing of or send the appliance to a recycling centre. Dispose of the electronics at corresponding collection centres.

We offer our customers to dispose of their waste appliances. Please contact us or one of our distribution partners.

Packaging and packing material can be sent to the recycling centre by indicating the waste disposal contract number. If you do not have the valid waste disposal contract number, you can request it from [HUPFER®](#) Customer Service.

NOTE**Disposal of electrical equipment**

Electrical equipment is not a part of household refuse.

Please return the machine to the manufacturer for disposal purposes:

HUPFER® Metallwerke GmbH & Co. KG

Dieselstraße 20

48653 Coesfeld

Germany

☎ +49 2541 805-0

📠 +49 2541 805-111

www.hupfer.de

info@hupfer.de

5 Operation

DANGER

Defective emergency stop



In case of fault, e.g. from defective fuses, the drives may continue to run even after the emergency stop has been pressed.

ATTENTION

Rotating machine parts



There is an indirect risk of injuries of the fingers caused by being pulled into the appliance and crushing.

Avoid any direct contact with the running round belt and the outlet, feeding and deflection points during operation or when performing any other work.

Never reach into the hazardous area of the conveyor system during operation. Before switching on the conveyor system, make sure there is no risk of reactivation of the belt.

5.1 Arrangement and Function of the Operating Elements

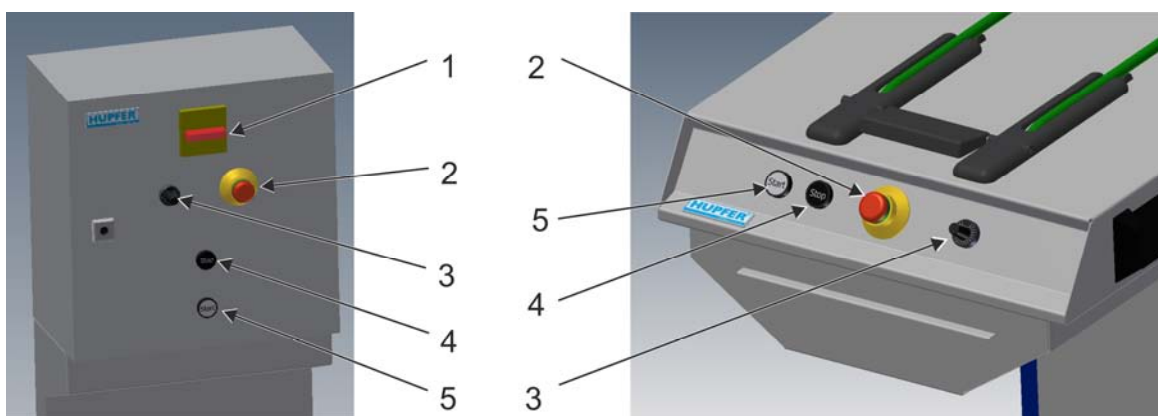

Figure 6 Operating elements SGR and SPV

- | | | | |
|---|------------------------|---|--------------|
| 1 | Main switch (SGR only) | 4 | Stop button |
| 2 | Emergency Stop button | 5 | Start button |
| 3 | Potentiometer | | |

Position number	Operating element	Function
1	Main switch (SGR only)	Switches the conveyor system on.
2	Emergency Stop button	Is used to switch off the appliance quickly in case of emergency. If you have pressed the Emergency Stop button, the power supply of the drives of the whole conveyor system will be interrupted.
3	Potentiometer	Controls the speed of the belt: V min. = 13 ft/min. (4 m/min.) V max. = 66 ft/min. (20 m/min.)
4	Stop button	Stops the conveyor system if needed.
5	Start button	Starts the conveyor system

5.2 Operation

ATTENTION

Rotating machine parts



There is an indirect risk of injuries of the fingers caused by being pulled into the appliance and crushing.

Avoid any direct contact with the running round belt and the outlet, feeding and deflection points during operation or when performing any other work.

Never reach into the hazardous area of the conveyor system during operation. Before switching on the conveyor system, make sure there is no risk of reactivation of the belt.

ATTENTION

Rotating machine parts



There is the risk from the running round belt of crush-type injuries and being pulled into the appliance when the conveyor system is in operation.

Ensure when working at the conveyor system that one's fingers do not get caught under the round belts. Do not wear any loose-fitting clothing, such as scarves or ties, during operations.

Place the trays on the conveyor belt uniformly to ensure smooth transportation.

The conveyor system keeps on running automatically. If required, you can manually intervene in the conveying process via the operating console.

Switching on:

- Set the main switch (1) from the switch position 0 to the switch position 1. As a result, the conveyor system will switch on.
- Unlock the Emergency Stop button. The conveyor system is ready for operation.
- Set the belt speed on the potentiometer (4) to the value 1-2.
- Press the green start button (3) or the foot switch (option) to start the conveyor system.

Switching off / stop:

- The belt of the conveyor system will automatically stop moving if the belt limit switch has been applied.
- Press the black stop button (2) or the foot switch (option) to stop the conveyor system if required.
- Set the main switch (1) from the switch position 1 to the switch position 0. As a result, the conveyor system will switch off.

5.3 Measures at the End of Use

ATTENTION

Rotating machine parts



There is an indirect risk of injuries of the fingers caused by being pulled into the appliance and crushing.

Avoid any direct contact with the running round belt and the outlet, feeding and deflection points during operation or when performing any other work.



Wait until the belt comes to a standstill.

To take the conveyor system out of operation, proceed as follows:

- Do not put further trays onto the conveyor belt or make sure that the conveyor belt is cleared up.
- Switch off the conveyor system on the operating console.
- Disconnect the conveyor system from the mains with the main switch.

6 Troubleshooting and Repair

6.1 Safety Measures

DANGER	Hazardous electrical voltage
	<p>Electrical current can pose a considerable threat to life and physical well-being and may lead to injuries.</p> <p>Before examining the appliance for faults, take the conveyor system out of operation and secure it against unauthorised reactivation.</p>
DANGER	Defective emergency stop
	<p>In case of fault, e.g. from defective fuses, the drives may continue to run even after the emergency stop has been pressed.</p>
ATTENTION	Rotating machine parts
	<p>There is an indirect risk of injuries of the fingers caused by being pulled into the appliance and crushing.</p> <p>Avoid any direct contact with the running round belt and the outlet, feeding and deflection points during operation or when performing any other work.</p> <p>Never reach into the hazardous area of the conveyor system.</p>

6.2 Instructions regarding Fault Repair

Servicing should be carried out by authorised specialists only.

Defective components should only be replaced with **HUPFER®** original parts. The modular design simplifies the replacement of individual components.

In the event of after-sales service and when ordering spare parts specify always the data given in the rating plate.

Regular inspections and maintenance of the appliance prevent disruptions to operation and ensure safety.

6.3 Fault and Action Table

Only a specialist staff authorised by HUPFER® may perform troubleshooting work.

Fault	Cause	Measures
The conveyor system does not run	Defective on site fuses	Have checked by a qualified electrician
	Defective mains connecting lead or mains plug	Have the disruption checked and repaired by a qualified electrician.
	Defective switch device	Have the disruption checked and repaired by a qualified electrician.
	Emergency Stop button has been pressed (the green ring cannot be seen)	Unlock the Emergency Stop button (the green ring is visible)
	Main switch is not turned on	Turn on the main switch
	Final shut-down of the transportation system assigned	Clearing off the transportation system and keeping it clear

Fault	Cause	Measures
The speed cannot be adjusted	Reflector dirty or faulty (if available)	Clean the reflector with a cloth or replace
	Dirty light barrier (if available)	Clean with a cloth
	Defective light barrier (if available)	Have the fault checked and repaired by a qualified electrician
	Defective fine fuses	Have the fault checked and repaired by a qualified electrician
	Energy optimisation device switches on	Have the fault checked and repaired by a qualified electrician
	Mechanical rocker limit switch sticks (if available)	Clean and lubricate. If needed, have the fault checked and repaired by a qualified electrician
	Foot switch is not activated (if available)	Press the foot switch
Motor does not run	Defective potentiometer or control unit	Have the fault checked and repaired by a qualified electrician
The conveyor system does not convey	Fuse is blown	Have the fuses checked and replaced by a qualified electrician, if required
	Overload protection has been triggered	Switch on the overload protection and have the fault checked and repaired by an qualified electrician
	Defective motor control unit (frequency converter)	Have the control unit checked and replaced by a qualified electrician, if required
	Defective motor	Have the motor checked and replaced by a qualified electrician, if required
The conveyor system conveys too quickly	The conveyor belt is overloaded, the drive spins around	Take some loads from the conveyor belt and if needed check and re-stretch the round belt
The conveyor systems does not switch off	Frequency converter setting is too high	The parameter should be set by a qualified electrician
Running noises	Defective relay	Have the fault checked and repaired by a qualified electrician
	Defective light barrier (if available)	Have the fault checked and repaired by a qualified electrician
	Defective button	Have the fault checked and repaired by a qualified electrician
	Defective control system	Have the fault checked and repaired by a qualified electrician
Conveyor belt run, one-sided	There is a lot of free space for the round belt or the round belt is stretched too much	Check and, if needed, restretch the belt
	Defective bearings in the casters	Replace the casters
Round belt snaps	Dirty or sticky surface	Clean with water
	The round belt is stretched on one side	Check and, if needed, restretch the belt
Tray runs obliquely	Drive and deflector rollers or structure are dirty	Clean with water and washing-up liquid
Trays queue up in the bends	Round belt poorly welded or tangled	Restretch and weld the round belt
	The tension is too low	Restretch and weld the round belt
	Distance between trays is not sufficient	Have a specialist set a greater distance at the frequency converter.

7 Care and Maintenance

7.1 Safety Measures

DANGER

Hazardous electrical voltage



Electrical current can pose a considerable threat to life and physical well-being and may lead to injuries.

Before performing cleaning and maintenance work, take the conveyor system out of operation and secure it against unauthorised reactivation.

ATTENTION

Rotating machine parts



There is a risk of injury caused by being pulled into the appliance and crushing.

Before performing cleaning and maintenance work, take the conveyor system out of operation and secure it against unauthorised reactivation. Avoid any direct contact with the running round belt and the outlet, feeding and deflection points when performing any other work.

Never reach into the hazardous area of the conveyor system.

ATTENTION

Risk of damages to property



Due to poor maintenance there is a risk of injury and damages to property.

Meet the maintenance intervals and the specified deadlines for regular checks and inspections.

7.2 Hygiene Measures

It is essential for operating staff to act in the correct manner to ensure optimal hygiene.

All persons must be informed about the locally valid hygiene regulations, observe them and comply with them.

Use a waterproof plaster to cover wounds on hands and arms.

Never sneeze or cough on clean trays.

7.3 Notes on Care and Maintenance Measures

ATTENTION

Appliance damages



Never use chloride-containing cleaning agents, abrasive cleaning powder or steel wool to clean the operating elements. Aggressive cleaning agents can destroy plastics and scratch the display.

Use lukewarm water and a soft cloth to clean the control panel.

The use of degreasing, chlorine-free agents (e.g. soapy water used normally in kitchens) and cleaning cloth is sufficient for cleaning. In no case clean the PVC surfaces with solvents and aggressive substances.

- Clean the round belt
- Clean the surface of the conveyor system
- Clean the dirty photo cell with a cloth and regularly clean the limit switch.
- Patient drawers are only to be cleaned when empty. The patient drawer must be pulled out. During wet cleaning ensure that the water deposits are removed.

- Regularly carry out a functional test on the light barriers and clean the optical equipment.
- Take out the perforated plate in order to clean the collecting basin.

Dry well the conveyor system after the wet and moist cleaning to avoid the development of mould and growth of germs and bacteria. Let the conveyor belt dry well after cleaning.

7.3.1 Maintenance

To ensure a long-lasting lifetime of the conveyor system, the regular maintenance is required. Appeared faults or damages must be immediately eliminated.

NOTE	Handling lubricants
When handling oils, greases and other chemical substances, follow the safety instructions which apply to them.	

Maintenance measures	Action	daily	weekly	monthly	Interval
Visual inspection of the conveyor system for mechanical damages	Carry out		x		
Round belt as to correct tension	Check				x ¹
Visual inspection of the electrical installation	Carry out				x ¹
Connecting lead and mains plug for mechanical damages	Check				x ¹
Protective earth conductor and protection device	Check				x ¹
Function of the main switch	Check			x	
Function of the Emergency Stop button	Check			x	
Engine box and deflection box	Clean			x	
Function of the mechanical parts	Check			x	
Round belt for damages and wear	Check				x ¹
Bearing of the drive and deflection side	Check			x	
Function of the limit switch	Check			x	
Function of the conveyor rollers	Check			x	

x¹ = every 6 months

7.3.2 Restretch the Round Belt

ATTENTION	Risk of injury from snapping round belts
	Tensioning may cause the round belt to snap and shoot upwards. Work together with another person. Hold the ends of the round belt as near as possible to the point of connection. Wear protective goggles and safety gloves during the entire assembly procedure.

NOTE	Shorten round belts
On the tension easing, the round belts must be shortened by approx. 0.4" (1 cm) per metre run.	

Insufficient tension of the round belts may lead to an uneven speed of the conveyor belt, racing of the drive wheels and to running noises. The round belts must be separated and re-welded. Fracture or an incipient crack is also a reason for restretching and welding the round belts.

- Before separation ensure that the round belt is fixed at the weld from both sides.
- Given a fracture, incipient crack or insufficient tension, accurately sever the round belt at the weld using a knife or scissors.
- Weld the round belts and at the same time follow the procedure laid down in Section 'Assembling the round belts'.

7.4 Special Care Instructions

Resistance to corrosion in stainless steel is provided by a passive layer which is formed on the surface when oxygen is absorbed. The oxygen in air is sufficient to form the passive layer, so that damage caused by physical action is eliminated automatically.

The passive layer develops or is renewed more quickly when the steel comes into contact with water containing oxygen. The passive layer can be chemically damaged or breached by agents which have a reducing (oxygen-consuming) effect when they come into contact with steel at concentrated levels or at high temperatures.

Such aggressive substances include:

- substances containing salt and sulphur
- chlorides (salts)
- seasoning concentrates (e.g. mustard, vinegar essence, seasoning cubes, saline solutions)

Further damages can occur due to:

- extraneous rust (e.g. from other components, tools or rust film)
- iron particles (e.g. grinding dust)
- contact with non-ferrous metals (element formation)
- lack of oxygen (e.g. no admission of air, low-oxygen water).

General working principles for handling appliances made of "refined stainless steel":

- Always keep the surface of appliances made from stainless steel clean and open to air.
- Use cleaning agents suitable for stainless steel. Never use bleaching cleaning agents or any containing chlorides.
- Remove layers of lime scale, grease, starch and egg-white by cleaning daily. Corrosion may occur underneath these layers due to lack of air absorption.
- Remove all cleaning agent residues by wiping thoroughly with plenty of water each time that you clean. The surface should be thoroughly dried after wiping.
- Do not bring parts made of stainless steel into contact with substances such as concentrated acids, seasonings and salts for longer than is absolutely necessary. Acid fumes emitted when tiles are cleaned also cause corrosion in "refined stainless steel".
- Avoid damaging the surface of the stainless steel, especially by bringing into contact with metals other than stainless steel.
- Residues from other metals produce extremely small amounts of chemical elements which can cause corrosion. Contact with iron and steel must be avoided at all costs, because it will cause extraneous rust. If stainless steel comes into contact with iron (steel wool, steel particles from pipes, water containing iron), this can trigger corrosion. You must therefore use refined steel wool or brushes with natural, plastics or refined steel bristles only for physical cleaning. Steel wool or brushes with unalloyed steel cause extraneous rust due to abrasion.

8 Spare Parts and Accessories

8.1 Introduction

Servicing should be carried out by authorised specialists only.

Defective components should only be replaced with **HUPFER®** original parts or identical spare parts. That is the only way to guarantee a safe operation. We must inform you that a perfect functionality of the appliance can only be ensured if you use recommended original parts by **HUPFER®**. Unsuitable or partially suitable spare parts can void the warranty.

Spare parts and accessories can be ordered at **HUPFER®** Service (Tel. +49 2541 805-0). When ordering spare parts or after-sales services, always specify the order number and specifications on the rating plate. Please specify the required round belt length when ordering spare parts.

8.2 Spare Parts and Accessories List

SGR | SPV

Drawing number	Item designation	Type	
0116301299	Gear motor	iFU 400V 50Hz 42Nm	
015209203	Drive wheel	Al Mg3 Ø131/17/37 set	(Package contains 2 units)
0116300367	Shaft	Ø18/234	Stainless steel
015223002	Caster	PE500 Ø40/30 black	
015223001	Bearing	RK 6003.2RS stainless steel Ø35/ Ø17/10 ET	
0116301074	Deflection wheel	Ø131/22	Aluminium
0116301076	Shaft	Ø17/230	Stainless steel
015002098	Round belt guide	HDPE 25/15/19 black set	(Package contains 10 units)
015002110	Round belt	Green Ø 12 mm	Variable length
0191093370	Button	Emergency Stop 1S 1Ö complete	
0116300656	Button	"Start" 51/41/30 grey	Polymer
0116300657	Button	"Stop" 51/41/30 grey	Polymer
0191028022	Potentiometer	77/41/30 complete	
0191163394	Sensor	Reed magnetic 1Ö	
0191008557	Light barrier	E3S-AR 31	
0116300658	Foot switch	PA66 72/97/28 12 - 230V black	
0191100340	Floor fastening	Stainless steel 105/75/52 cpl	Stainless steel
0191128732	Holder	38/18/10 black	Polymer
0191042205	Magnet	Ø15/5 adhesive force 90N	
014002525	Threaded leg	PA Ø70/170 40x40 black set	(Package contents: 2 piece)

9 Annex

9.1 Monthly Maintenance Checklist

Conveyor belt systems (Round belt)		Function	Cleanness	Condition/ wear	Replace part	Date and maintenance
1	Check the function of the main switch					
2	Check the function of the Emergency Stop button					
3	Clean the engine box and deflection box					
4	Check the function of the mechanical parts					
5	Check the round belts for damages and wear					
6	Check the tension of the round belts					
7	Check the bearing of the drive and deflection side					
8	Check the function of the limit switch					
9	Check the function of the conveyor rollers					
10	Check the chain tension					
11	Lubricate the chain					

9.3 EC Declaration of Conformity

CE Konformitätserklärung

Declaration of CE-Conformity | Déclaration de conformité CE



Gegenstand | Object | Objet
Geschirr-Rücklaufband | crockery return belt | Bande de retour de la vaisselle

Artikelgruppe | Article category | Groupe d'articles
SGR

Typ | Type | Type
Ohne Heizung/Kühlung | without heating/cooling | sans chauffage/refroidissement

Es wird bescheinigt, dass das/die zuvor näher beschriebene/n Produkt/e der/den im Folgenden aufgelisteten EU-Richtlinie/n entspricht/entsprechen:

98/37/EG, 2006/95/EWG, 2004/108/EG

Darüber hinaus wurden folgende harmonisierte Normen angewandt:

EN ISO 14121-1, EN ISO 12100-1, EN ISO 12100-2, EN 614-1, EN 1037, EN 349, EN ISO 13857, EN 60204-1, EN 61140, EN 61000-6-2, EN 61000-6-4

Im Übrigen wird bescheinigt, dass das/die Produkt/e weder Störungsquellen noch störungsanfällige Bauteile im Sinne der EMV-Richtlinie enthält/enthalten.

It is certified that the product/s described in detail before, conform/s to the requirements of the European Union directive/s listed in the following:

98/37/EC, 2006/95/EWG, 2004/108/EC

Furthermore, the following harmonised standards have been applied:

EN ISO 14121-1, EN ISO 12100-1, EN ISO 12100-2, EN 614-1, EN 1037, EN 349, EN ISO 13857, EN 60204-1, EN 61140, EN 61000-6-2, EN 61000-6-4

Incidentally, it is certified that the product/s contain/s neither sources of disturbance nor components liable to disturbances according to the EMC directive.

Il est certifié que le/s produit/s décrit/s en détail ci-dessus, correspond/ent aux directive/s de l'UE énuméré/es dans ce qui suit:

98/37/CE, 2006/95/EWG, 2004/108/CE

En outre, les normes harmonisées suivantes ont été appliquées:

EN ISO 14121-1, EN ISO 12100-1, EN ISO 12100-2, EN 614-1, EN 1037, EN 349, EN ISO 13857, EN 60204-1, EN 61140, EN 61000-6-2, EN 61000-6-4

Il est certifié aussi, que le/s produit/s ne contient/contiennent ni des sources de perturbation ni des éléments de construction exposés à des perturbations correspondant aux directives de l'AECM.

Coesfeld, 09.08.2010

Helmut Schumacher Vorname, Nachname	Geschäftsführung Position	Unterschrift
---	-------------------------------------	--------------

Jürgen Gottwald Vorname, Nachname	Leiter Normenstelle Position	Unterschrift
---	--	--------------

Dokumentationsbevollmächtigter Jürgen Gottwald	HUPFER® Metallwerke GmbH & Co. KG	info@hupfer.de
--	--------------------------------------	----------------

Diese Konformitätserklärung ist eine original Konformitätserklärung in deutscher Sprache und kann gleichlautende Übersetzungen in weiteren EU-Sprachen enthalten. This declaration of conformity is an original declaration of conformity in the German language and can contain identical translations in the other EU languages. Cette déclaration de conformité est une déclaration de conformité originale en langue allemande et peut contenir des traductions conformes en d'autres langues de l'UE.

HUPFER® Metallwerke GmbH & Co KG
Dieselstraße 20 | 48653 Coesfeld | Deutschland | +49 2541 805-0 | info@hupfer.de



CE Konformitätserklärung

Declaration of CE-Conformity | Déclaration de conformité CE

Gegenstand | Object | Objet
Speisenverteilterband | food distribution belt | Tapis de distribution des repas

Artikelgruppe | Article category | Groupe d'articles
SPV

Typ | Type | Type
Ohne Heizung/Kühlung | without heating/cooling | sans chauffage/refroidissement

Es wird bescheinigt, dass das/die zuvor näher beschriebene/n Produkt/e der/den im Folgenden aufgelisteten EU-Richtlinie/n entspricht/entsprechen:

2006/42/EG, 2006/95/EWG, 2004/108/EG

Darüber hinaus wurden folgende harmonisierte Normen angewandt:

EN ISO 14121-1, EN ISO 12100-1, EN ISO 12100-2, EN 614-1, EN 1037, EN 349, EN ISO 13857, EN 60204-1, EN 61140, EN 61000-6-2, EN 61000-6-4

Im Übrigen wird bescheinigt, dass das/die Produkt/e weder Störungsquellen noch störungsanfällige Bauteile im Sinne der EMV-Richtlinie enthält/enthalten.

It is certified that the product/s described in detail before, conform/s to the requirements of the European Union directive/s listed in the following:

2006/42/EG, 2006/95/EWG, 2004/108/EC

Furthermore, the following harmonised standards have been applied:

EN ISO 14121-1, EN ISO 12100-1, EN ISO 12100-2, EN 614-1, EN 1037, EN 349, EN ISO 13857, EN 60204-1, EN 61140, EN 61000-6-2, EN 61000-6-4

Incidentally, it is certified that the product/s contain/s neither sources of disturbance nor components liable to disturbances according to the EMC directive.

Il est certifié que le/s produit/s décrit/s en détail ci-dessus, correspond/ent aux directive/s de l'UE énuméré/es dans ce qui suit:

2006/42/CE, 2006/95/EWG, 2004/108/CE

En outre, les normes harmonisées suivantes ont été appliquées:

EN ISO 14121-1, EN ISO 12100-1, EN ISO 12100-2, EN 614-1, EN 1037, EN 349, EN ISO 13857, EN 60204-1, EN 61140, EN 61000-6-2, EN 61000-6-4

Il est certifié aussi, que le/s produit/s ne contient/contiennent ni des sources de perturbation ni des éléments de construction exposés à des perturbations correspondant aux directives de l'AECM.

Coesfeld, 09.08.2010

Helmut Schumacher
Vorname, Nachname

Geschäftsführung
Position

Unterschrift

Jürgen Gottwald
Vorname, Nachname

Leiter Normenstelle
Position

Unterschrift

Dokumentationsbevollmächtigter
Jürgen Gottwald

HUPFER® Metallwerke
GmbH & Co. KG

info@hupfer.de

Diese Konformitätserklärung ist eine original Konformitätserklärung in deutscher Sprache und kann gleichlautende Übersetzungen in weiteren EU-Sprachen enthalten. This declaration of conformity is an original declaration of conformity in the German language and can contain identical translations in the other EU languages. Cette déclaration de conformité est une déclaration de conformité originale en langue allemande et peut contenir des traductions conformes en d'autres langues de l'UE.

HUPFER® Metallwerke GmbH & Co KG
Dieselstraße 20 | 48653 Coesfeld | Deutschland | +49 2541 805-0 | info@hupfer.de

